

VANNES à SPHÈRE en LAITON à 3 Voies avec Poigné Acier

Série V-396L / T



Schéma de manoeuvre V396-L
Operation draft V396-L



Schéma de manoeuvre V396-T
Operation draft V396-T

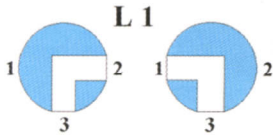

DN	1/4"	3/8"	1/2"	3/4"	1"	1 1/4"	1 1/2"	2"
Ø	10	10	12	15	20	25	32	40
F	12	12	14	16	19	21	23	26
S	74	74	80	90	105	115	138	161
H	58	58	60	64	73	79	100	105
L	90	90	125	125	140	140	220	220
A	22	22	24	28	31	35	42	48
B	37	37	39	46	52	58	69	80
Ch	22	22	29	34	42	50	57	68

Diagramme Perte de Charge - *Flow and pressure drop*

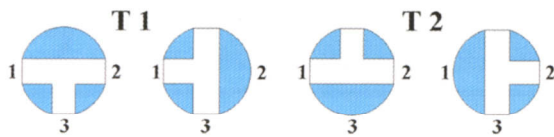
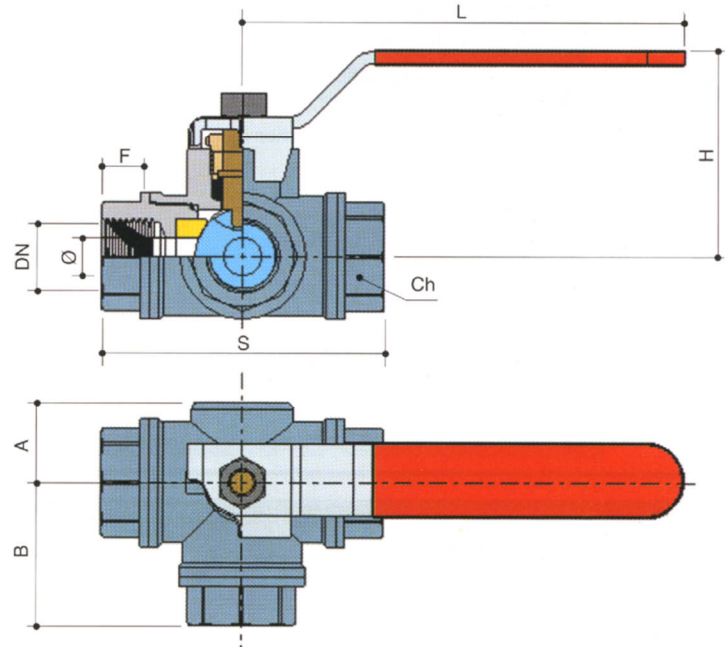
Dimension en mm

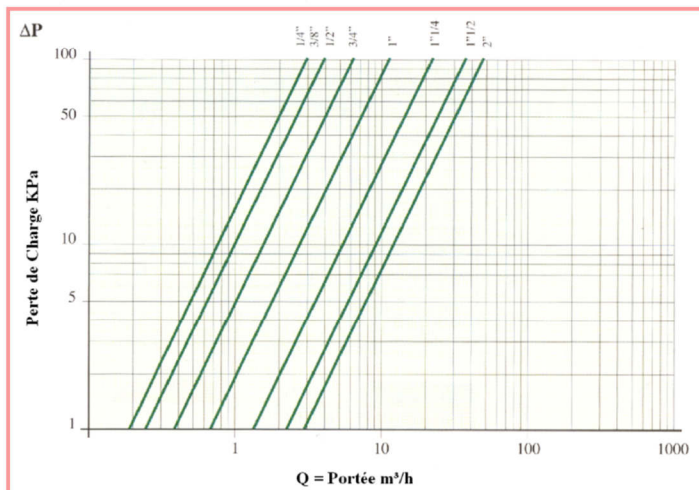

Coeff. Kw - <i>Kw Factor</i>	
1/4" - 10	3
3/8" - 10	3
1/2" - 12	4
3/4" - 15	6
1" - 20	12
1 1/4" - 25	21
1 1/2" - 32	35
2" - 40	47